





**QD SPROCKETS FOR CHAIN 41-1(1/2" Pitch)**  
**SPROCKETS TYPE B**

Chain: Pitch:  
Internal width:  
Roller dia.:

Sprocket: Tooth radius r:  
Radius width C:  
Tooth width h1:  
Tooth width h2:  
Tooth width h3:  
Full high H: -

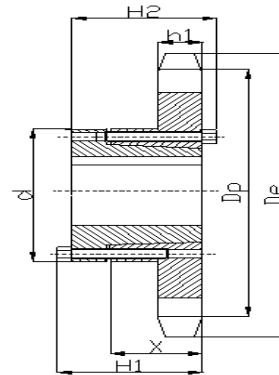

Teeth	De	Dp	Simplex					Type
			d	H 1	H 2	Bush	X	
15	2.65	2.405	2 1/16	1 1/8	1 1/8	JA	5/8	B
16	2.81	2.503				JA		B
17	2.98	2.721				JA		B
18	3.14	2.879				JA		B
19	3.3	3.038	2 1/16	1 1/8	1 1/8	JA	5/8	B
20	3.46	3.196	2 11/16	1 7/16	1 7/16	SH	13/16	B
21	3.62	3.355				SH		B
22	3.78	3.573				SH		B
23	3.94	3.672				SH		B
24	4.1	3.831				SH		B
25	4.26	3.989				SH		B
26	4.42	4.148				SH		B
27	4.58	4.307				SH		B
28	4.74	4.466				SH		B
30	5.06	4.783				SH		B
32	5.38	5.101				SH		B
35	5.86	5.578	2 11/16	1 7/16	1 7/16	SH	13/16	B
36	6.02	5.737	3 3/16	1 1/2	1 1/2	SDS	3/4	B
40	6.65	6.373				SDS		B
42	6.97	6.691				SDS		B
45	7.45	7.168				SDS		B
48	7.93	7.645				SDS		B
54	8.89	8.599				SDS		B
60	9.84	9.554	3 3/16	1 1/2	1 1/2	SDS	3/4	B
70	11.43	11.145	3 7/8	2 1/8	2 1/8	SK	1 1/4	B
72	11.75	11.463				SK		B
80	13.03	12.736				SK		B
84	13.66	13.372				SK		B
96	15.57	15.281				SK		B
112	18.12	17.828	3 7/8	2 1/8	2 1/8	SK	1 1/4	B



**QD SPROCKETS FOR CHAIN 40-1/-2/-3(1/2" Pitch)  
SPROCKETS TYPE B & TYPE C**

Chain: Pitch: 12.7mm  
Internal width: 7.85mm  
Roller dia.: 7.92mm

Sprocket: Tooth radius r:  
Radius width C:  
Tooth width h1:  
Tooth width h2:  
Tooth width h3:  
Full high H: -

Note:△with hardened teeth, Simplex with 30 teeth or less

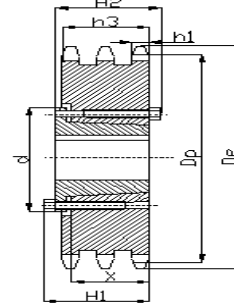
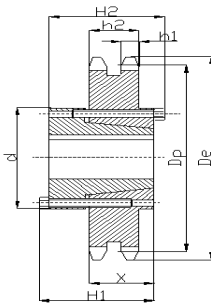
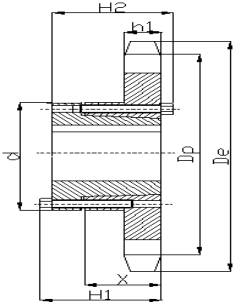

Teeth	De	Dp	Simplex						Duplex						Triplex						
			d	H 1	H 2	Bush	X	Type	d	H 1	H 2	Bush	X	Type	d	H 1	H 2	Bush	X	Type	
△15	2.65	2.405	2 1/16	1 1/8	1 1/8	JA	5/8	B													
△16	2.81	2.503				JA		B													
△17	2.98	2.721				JA		B													
△18	3.14	2.879				JA		B													
△19	3.3	3.038	2 1/16	1 1/8	1 1/8	JA	5/8	B													
△20	3.46	3.196	2 11/16	1 7/16	1 7/16	SH	13/16	B													
△21	3.62	3.355				SH		B													
△22	3.78	3.573				SH		B													
△23	3.94	3.672				SH		B													
△24	4.1	3.831				SH		B													
△25	4.26	3.989				SH		B													
△26	4.42	4.148				SH		B													
△27	4.58	4.307				SH		B													
△28	4.74	4.466				SH		B													
△30	5.06	4.783				SH		B													
32	5.38	5.101				SH		B													
35	5.86	5.578	2 11/16	1 7/16	1 7/16	SH	13/16	B													
36	6.02	5.737	3 3/16	1 1/2	1 1/2	SDS	3/4	B	2 5/8	2 1/8	2 1/8	SK	1 1/4	C	3 7/8	2 1/8	2 1/8	SK	1 1/4	B	
40	6.65	6.373				SDS		B				SK		C							
42	6.97	6.691				SDS		B				SK		C				SK		B	
45	7.45	7.168				SDS		B				SK		C							
48	7.93	7.645				SDS		B				SK		C				SK		B	
52	8.57	8.281										SK		C				SK		B	
54	8.89	8.599				SDS		B				SK		C							
60	9.84	9.554	3 3/16	1 1/2	1 1/2	SDS	3/4	B	2 5/8	2 1/8	2 1/8	SK	1 1/4	C	3 7/8	2 1/8	2 1/8	SK	1 1/4	B	
68	11.12	10.826							2 15/16	2 1/4	2 1/4	SF	1 1/4	C	4 5/8	2 1/4	2 1/4	SF	1 1/4	B	
70	11.43	11.145	3 7/8	2 1/8	2 1/8	SK	1 1/4	B													
72	11.75	11.463				SK		B				SF		C				SF		B	
76	12.39	12.099										SF		C				SF		B	
80	13.03	12.736				SK		B													
84	13.66	13.372				SK		B				SF		C				SF		B	
95	15.41	15.122										SF		C				SF		B	
96	15.57	15.281				SK		B													
102	16.53	16.236										SF		C	4 5/8	2 1/4	2 1/4	SF	1 1/4	B	
112	18.12	17.828	3 7/8	2 1/8	2 1/8	SK	1 1/4	B	2 15/16	2 1/4	2 1/4	SF	1 1/4	C							



**QD SPROCKETS FOR CHAIN 50-1/-2/-3(5/8" Pitch)  
SPROCKETS TYPE B,TYPE B1&TYPE C**

Chain: Pitch: 15.875mm  
Internal width: 9.4mm  
Roller dia.: 10.16mm

Sprocket: Tooth radius r:  
Radius width C:  
Tooth width h1:  
Tooth width h2:  
Tooth width h3:  
Full high H: -

Note:△with hardened teeth,Simplex with 30 teeth or less, Triplex with 25 teeth or less

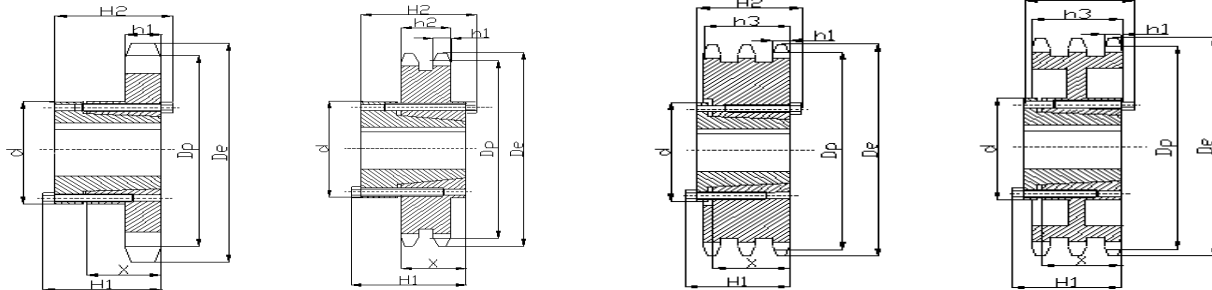

Teeth	De	Dp	Simplex						Duplex					Triplex							
			d	H 1	H 2	Bush	X	Type	d	H 1	H 2	Bush	X	Type	d	H 1	H 2	Bush	X	Type	
△12	2.71	2.415	2 1/16	1 1/8	1 1/8	JA	5/8	B													
△13	2.91	2.612				JA		B													
△14	3.11	2.803				JA		B													
△15	3.32	3.006				JA		B													
△16	3.52	3.204	2 1/16	1 1/8	1 1/8	JA	5/8	B													
△17	3.72	3.401	2 11/16	1 7/16	1 7/16	SH	13/16	B													
△18	3.92	3.599	2 11/16	1 7/16	1 7/16	SH	13/16	B													
△19	4.12	3.797	2 11/16	1 7/16	1 7/16	SH	13/16	B													
△20	4.32	3.995	3 3/16	1 1/2	1 1/2	SDS	3/4	B													
△21	4.52	4.194				SDS		B													
△22	4.72	4.392				SDS		B													
△23	4.92	4.59				SDS		B													
△24	5.12	4.788				SDS		B													
△25	5.32	4.987				SDS		B													
△26	5.52	5.185				SDS		B													
△27	5.72	5.384				SDS		B													
△28	5.92	5.582				SDS		B													
△30	6.32	5.979				SDS		B													
32	6.72	6.376				SDS		B													
35	7.32	6.972				SDS		B													
36	7.52	7.171				SDS		B	3 7/8	2 1/8	2 1/8	SK	1 1/4	C	3 7/8	2 1/8	2 1/8	SK	1 1/4	B	
40	8.32	7.966				SDS		B													
42	8.72	8.363				SDS		B	3 7/8	2 1/8	2 1/8	SK	1 1/4	C	3 7/8	2 1/8	2 1/8	SK	1 1/4	B	
45	9.31	8.96				SDS		B													
48	9.91	9.556	3 3/16	1 1/2	1 1/2	SDS	3/4	B	3 7/8	2 1/8	2 1/8	SK	1 1/4	C	3 7/8	2 1/8	2 1/8	SK	1 1/4	B	
52	10.71	10.351							4 5/8	2 1/4	2 1/4	SF	1 1/4	C	4 5/8	2 1/4	2 1/4	SF	1 1/4	B	
54	11.11	10.749	3 7/8	2 1/8	2 1/8	SK	1 1/4	B				SF		C							
60	12.3	11.942				SK		B				SF		C				SF		B	
68	13.89	13.533						B				SF		C				SF		B	
70	14.29	13.931				SK		B													
72	14.69	14.329	3 7/8	2 1/8	2 1/8	SK	1 1/4	B				SF		C				SF		B1	
76	15.49	15.124						B				SF		C				SF		B1	
80	16.28	15.92	4 5/8	2 1/4	2 1/4	SF	1 1/4	B													
84	17.08	16.715				SF		B				SF		C				SF		B1	
95	19.27	18.903						B				SF		C				SF		B1	
96	19.47	19.102				SF		B													
102	20.66	20.295						B				SF		C	4 5/8	2 1/4	2 1/4	SF	1 1/4	B1	
112	22.65	22.285	4 5/8	2 1/4	2 1/4	SF	1 1/4	B	4 5/8	2 1/4	2 1/4	SF	1 1/4	C							









**QD SPROCKETS 120-1/-2(1 1/2" Pitch)  
SPROCKETS TYPE B,B1,C,C5&C6**

Chain: Pitch: 38.1mm  
Internal width: 25.22mm  
Roller dia.: 22.23mm

Sprocket: Tooth radius r:  
Radius width C:  
Tooth width h1:  
Tooth width h2:  
Tooth width h3:  
Full high H: -

Note:△with hardened teeth,Simplex with 30 teeth or less

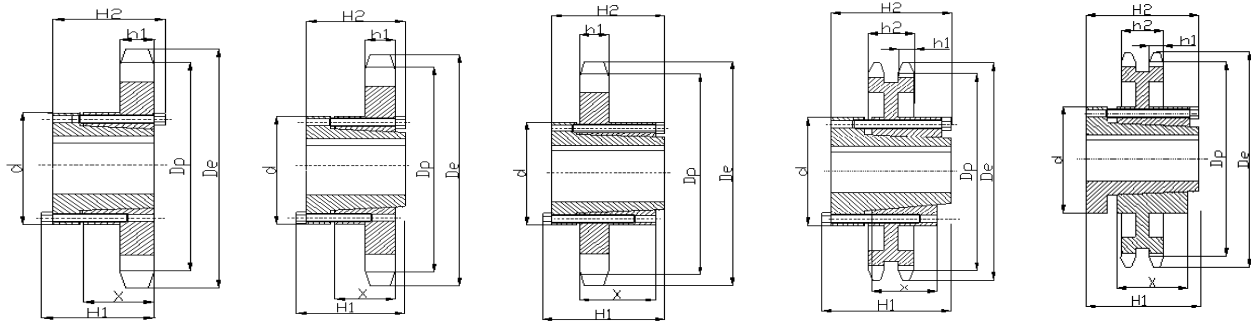

Teeth	De	Dp	Simplex						Duplex						
			d	H 1	H 2	Bush	X	Type	d	H 1	H 2	Bush	X	Type	
△12	6.5	5.796	4 5/8	2 1/4	2 1/4	SF	1 1/4	B							
△13	6.99	6.268				SF		B							
△14	7.47	6.741				SF		B							
△15	7.96	7.215	4 5/8	2 1/4	2 1/4	SF	1 1/4	B							
△16	8.44	7.689	6	2 15/16	2 5/8	E	1 5/8	B1							
△17	8.92	8.163				E		B1							
△18	9.41	8.638				E		B1							
△19	9.89	9.113				E		B1							
△20	10.37	9.589				E		B1							
△21	10.85	10.064				E		B1							
△22	11.33	10.54				E		B1							
△23	11.81	11.016				E		B1							
△24	12.29	11.492				E		B1							
△25	12.77	11.968				E		B1							
△26	13.25	12.444				E		B1							
△28	14.21	13.397				E		B1							
△30	15.17	14.35	6	2 15/16	2 5/8	E	1 5/8	B1	7 1/4	5	4 1/2	J	3 3/16	C5	
32	16.13	15.303	6 5/8	4	3 5/8	F	2 1/2	C							
35	17.57	16.734				F		C	7 1/4	5	4 1/2	J	3 3/16	C5	
36	18.05	17.211				F		C							
40	19.96	19.118				F		C							
45	22.35	21.503				F		C	7 1/4	5	4 1/2	J	3 3/16	C5	
48	23.79	22.935				F		C							
54	26.65	25.798	6 5/8	4	3 5/8	F	2 1/2	C							
60	29.52	28.661	7 1/4	5	4 1/2	J	3 3/16	C	9	6 3/4	6 3/4	M	5 3/16	C6	
70	34.3	33.434	7 1/4	5	4 1/2	J	3 3/16	C							
80	39.08	38.207	7 1/4	5	4 1/2	J	3 3/16	C							





**QD SPROCKETS FOR CHAINS 140-1/-2(1 1/2" Pitch)  
SPROCKETS TYPE B,B1,C,C1,C5&C6**

Chain: Pitch: 44.45mm  
Internal width: 25.22mm  
Roller dia.: 25.4mm

Sprocket: Tooth radius r:  
Radius width C:  
Tooth width h1:  
Tooth width h2:  
Tooth width h3:  
Full high H: -

Note:△with hardened teeth,Simplex with 30 teeth or less

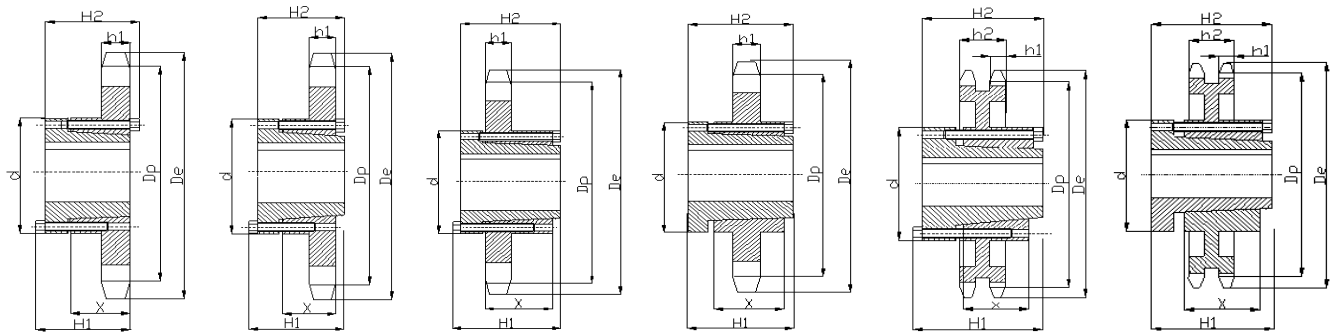

Teeth	De	Dp	Simplex							Duplex					
			d	H 1	H 2	Bush	X	Type	d	H 1	H 2	Bush	X	Type	
△11	7.01	6.212	4 5/8	2 1/4	2 1/4	SF	1 1/4	B							
△12	7.58	6.762	4 5/8	2 1/4	2 1/4	SF	1 1/4	B							
△13	8.15	7.313	4 5/8	2 1/4	2 1/4	SF	1 1/4	B							
△14	8.72	7.864	6	2 15/16	2 5/8	E	1 5/8	B1							
△15	9.28	8.417				E		B1							
△16	9.85	8.97				E		B1							
△17	10.41	9.524				E		B1							
△18	10.98	10.078				E		B1							
△19	11.54	10.632				E		B1							
△20	12.1	11.187				E		B1							
△21	12.66	11.742				E		B1							
△22	13.22	12.297	6	2 15/16	2 5/8	E	1 5/8	B1							
△23	13.78	12.852	6 5/8	4	3 5/8	F	2 1/2	B1							
△24	14.34	13.407				F		B1							
△25	14.9	13.963				F		B1							
△26	15.46	14.518				F		B1							
△30	17.7	16.742	6 5/8	4	3 5/8	F	2 1/2	B1							
35	20.49	19.523	6 5/8	4	3 5/8	F	2 1/2	C	7 1/4	5	4 1/2	J	3 3/16	C5	
36	21.05	20.079	6 5/8	4	3 5/8	F	2 1/2	C							
40	23.29	22.305	7 1/4	5	4 1/2	J	3 3/16	C							
45	26.08	25.087				J		C	7 1/4	5	4 1/2	J	3 3/16	C5	
54	31.1	30.097				J		C							
60	34.4	33.438	7 1/4	5	4 1/2	J	3 3/16	C	9	6 3/4	6 3/4	M	3 3/16	C6	
70	40.02	39.006	9	6 3/4	6 3/4	M	5 3/16	C1							
80	45.59	44.575	9	6 3/4	6 3/4	M	5 3/16	C1							



**QD SPROCKETS FOR CHAINS 160-1/-2(2" Pitch)  
SPROCKETS TYPE B1,C,C1&C6**

Chain: Pitch: 50.8mm  
Internal width: 31.55mm  
Roller dia.: 28.58mm

Sprocket: Tooth radius r:  
Radius width C:  
Tooth width h1:  
Tooth width h2:  
Tooth width h3:  
Full high H: -

Note:△with hardened teeth,Simplex with 30 teeth or less

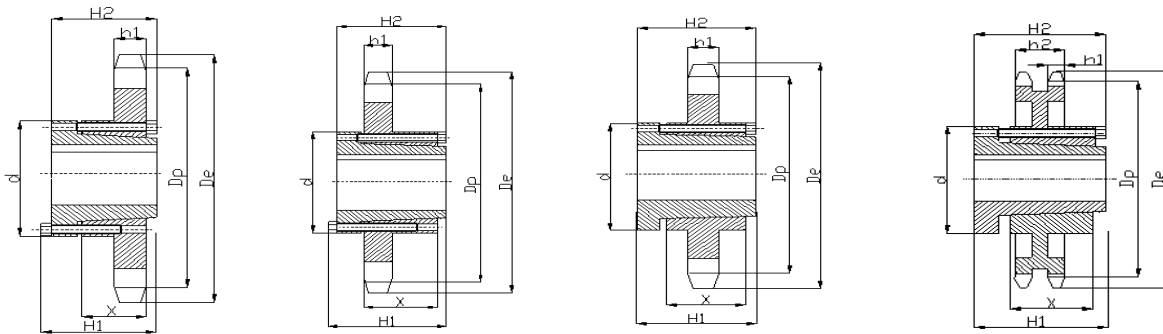

Teeth	De	Dp	Simplex						Duplex						
			d	H 1	H 2	Bush	X	Type	d	H 1	H 2	Bush	X	Type	
△12	8.66	7.727	6	2 15/16	2 5/8	E	1 5/8	B1							
△13	9.31	8.357	6	2 15/16	2 5/8	E	1 5/8	B1							
△14	9.96	8.988	6	2 15/16	2 5/8	E	1 5/8	B1							
△15	10.61	9.62	6 5/8	4	3 5/8	F	2 1/2	B1							
△16	11.26	10.252				F		B1							
△17	11.9	10.885				F		B1							
△18	12.54	11.518				F		B1							
△19	13.19	12.151				F		B1							
△20	13.83	12.785				F		B1							
△21	14.74	13.419				F		B1							
△22	15.11	14.053				F		B1							
△23	15.75	14.688				F		B1							
△24	16.39	15.323				F		B1							
△25	17.03	15.958	6 5/8	4	3 5/8	F	2 1/2	B1							
△26	17.67	16.593	7 1/4	5	4 1/2	J	3 3/16	C							
△28	18.95	17.863				J		C							
△30	20.23	19.134				J		C							
35	23.42	22.312	7 1/4	5	4 1/2	J	3 3/16	C	9	6 3/4	6 3/4	M	5 3/16	C6	
40	26.61	25.491	9	6 3/4	6 3/4	M	5 3/16	C1							
45	29.8	28.671				M		C1	10	8 1/8	8 1/8	N	6 1/4	C6	
54	35.54	34.397				M		C1							
60	39.36	38.215				M		C1	10	8 1/8	8 1/8	N	6 1/4	C6	
70	45.73	44.578				M		C1							
80	52.1	50.943	9	6 3/4	6 3/4	M	5 3/16	C1							



**QD SPROCKETS FOR CHAINS 200-1(2 1/2" Pitch)**  
**SPROCKETS TYPE C & TYPE C1**

Chain: Pitch: 63.5mm  
 Internal width: 37.85mm  
 Roller dia.: 39.68mm

Sprocket: Tooth radius r:  
 Radius width C:  
 Tooth width h1:  
 Tooth width h2:  
 Tooth width h3:  
 Full high H: -

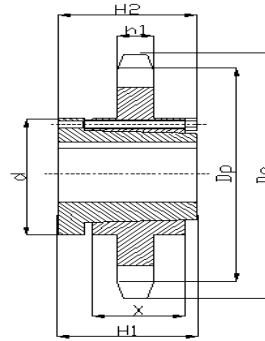
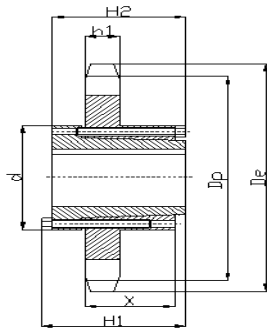

Teeth	De	Dp	Simplex					Type
			d	H 1	H 2	Bush	X	
12	10.83	9.66	6 5/8	4	3 5/8	F	2 1/2	C
13	11.64	10.447	7 1/4	5	4 1/2	J	3 3/16	C
14	12.46	11.235				J		C
15	13.26	12.025				J		C
16	14.07	12.815	7 1/4	5	4 1/2	J	3 3/16	C
17	14.87	13.605	9	6 3/4	6 3/4	M	5 3/16	C1
18	15.68	14.397				M		C1
19	16.48	15.91				M		C1
20	17.29	15.982				M		C1
21	18.09	16.775				M		C1
22	18.89	17.567				M		C1
23	19.69	18.36				M		C1
24	20.49	19.152				M		C1
25	21.29	19.947				M		C1
26	22.09	20.74				M		C1
28	23.69	22.33				M		C1
30	25.29	23.917				M		C1
32	26.88	25.505				M		C1
35	29.28	27.89				M		C1
40	33.27	31.865	9	6 3/4	6 3/4	M	5 3/16	C1
45	37.25	35.84	10	8 1/8	8 1/8	N	6 1/4	C1
54	44.42	42.995	10	8 1/8	8 1/8	N	6 1/4	C1
60	49.2	47.767	10	8 1/8	8 1/8	N	6 1/4	C1